

# Airpura

AIR PURIFIERS

# C600-DLX

Specific Chemicals - VOCs

***Remove Specific Airborne Chemicals  
including Volatile Organic Compounds***

**The Airpura C600 DLX  
Enhanced Chemical Abatement Unit  
offers you:**

■ **26 lb enhanced impregnated activated carbon bed**

Adsorbs airborne chemicals including volatile organic compounds (VOCs)

■ **HEPA-barrier post filter**

Traps particles after the carbon bed

■ **560 CFM integrated fan / motor**

Largest CFM available in a portable unit

■ **Variable speed control**

Gives you flexible air flow options

■ **Proper contact times for effective filtration**

Correctly calibrated air flow / bed depth for efficient adsorption.

■ **Pressure sealed filter chamber**

Unique pressure seal on the filter chamber ensures all contaminants are filtered and non escape

■ **The Airpura Limited Warranty**

5 years parts 10 years labor

■ **Call our air quality experts**

For the solution to your air pollution problem

■ **Over 4000 chemicals can be removed**

Carbon blends are available to deal with over 4000 airborne chemicals including:

Ammonias  
Nitrous dioxide  
Nitrous trioxide  
Monoethylamine

Hydrogen Sulfide  
Mercury vapors  
Chlorine dioxide  
Hydrogen Bromide  
Sulfur dioxide

Hydrogen fluoride  
Hydrogen chloride  
Benzene  
Methylene Chloride  
Radioactive Iodine

Toulene  
Naphthene  
Pesticides  
Chlorine  
Mold Mycotoxins



***The Airpura C600 DLX***

Available in  
White / Black / Cream

### **Filter Life**

Carbon filters should be changed as needed in heavy applications and at least every 24 months in normal use. Airpura carbon canisters are refillable to save costs. HEPA Barrier filters should be changed every 12 months.

Pre-filters can be vacuumed from the exterior of the unit and should be changed every 12 months depending on use.

***Protect Yourself with Airpura High Efficiency Air Purification***

# Airpura

AIR PURIFIERS

# C600-DLX

Airborne Chemicals & VOCs

## Technical Specifications

### Odor, airborne chemical and VOC control

26 lbs super enhanced impregnated activated carbon 13" x 13" x 7.5"

### Carbon bed

3" deep x 570 sq" surface

### Air Flow 560 cfm

More cfm than any other portable unit available

### Pre-filter

570 sq in x 1in

### Post particle filter

306 sq in

### Size

### Weight

49lbs total

### Voltage Options

115 or 220 volts

### Watts

120 on high  
40 on low

### Sound Level

28.1 db on low (at 6 feet)  
62.3 db on high (560 cfm)  
(Room level 25.1 db)

### ETL Certified

Conforms to  
CSA C22.2 no 113  
ANSI / UL 507

Your Airpura Dealer

## Filtration system

Cleanable pre-filter  
Vacuum through grill and change every 12 months

26 lb Enhanced Impregnated Carbon filter  
Enhanced carbon to capture VOCs more efficiently

HEPA-Barrier post filter  
Traps carbon dust and particles

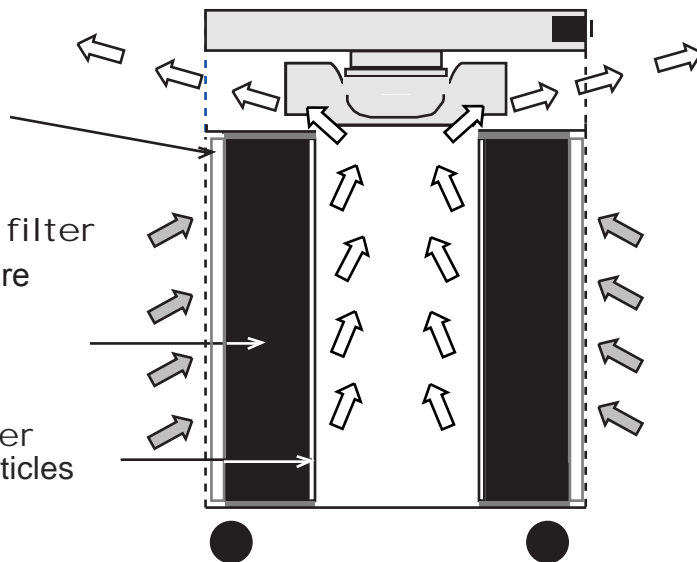

## Unique Features

- **All metal housing** ensures no plastic vapors are emitted.
- **Motor out of the air flow.** Most air purifiers blow the clean air over the motor and pick up impurities.
- **Electrical parts in a sealed chamber** out of the airflow. Increases safety and prevents off-gassing.
- **Pressure sealed filter chamber** prevents leakage of polluted air around filters.
- **Felt gaskets seal the filter chamber.** Maximize filtration with no rubber off-gassing found with other filters.
- **Clean modern appearance**
- **Low noise level**

## Specially designed to remove specific airborne chemicals and VOCs

### Dwell time

For best results the correct dwell time of the pollutants over the enhanced impregnated carbon bed is vital. The 560 CFM impeller/motor combined with the variable speed control and unimpeded airflow of the Airpura 600 series allows you to set the airflow precisely and achieve the results you need.

### Expertise you can call on

Airpura air quality experts can offer you a solution to most airborne chemical problems. Contact your Airpura dealer or call us directly to discuss your needs.

**Safe effective air filtration for your better health**