

7500 Central Air Filtration System



An Amaircare central air filtration system will effectively clean and circulate air throughout your entire home or office.

Three-Stage Filtration

Removes PARTICULATES, V.O.C.s (Volatile Organic Compounds) and ODORS.

Easy-to-Change Filters

Easy-access cover panels, and simple filter fastening system.

Durable Metal Cabinet

Greater protection for filters and internal components.

No Harmful By-Products

Emits no toxins such as OZONE

Independent Operation

Keeps working whether the furnace is running or not.

Continuous Air Flow

- Continuous supply of clean air
- Promotes more even air temperatures in the home

Customizable Installations

To suit the available space, Amaircare central systems can be installed free-standing or adapted to hang from a wall or ceiling. They can also be ducted to an HRV to filter the supplied outdoor air.

Installation Examples

The 7500 can be installed with existing furnace/air handling equipment, or it can be installed independently. Perfect for stand alone commercial or residential applications.

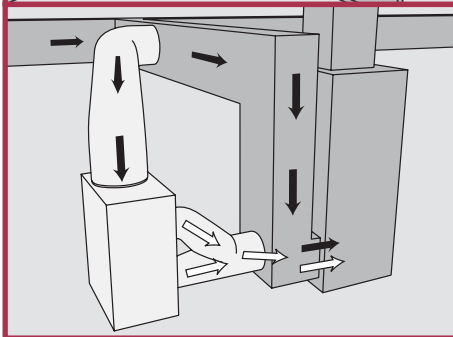
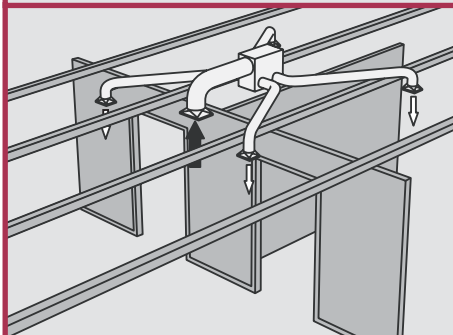

Specifications

DIMENSIONS: 17.25" W 28"L 33"H

WEIGHT: 82 lbs.

AIR FLOW (C.F.M.): 500-1,000

HEPA SURFACE AREA: 200 sq.ft.

POWER CONSUMPTION: 320 Watts

INTAKE: 14" duct collar

OUTFLOW: 2 (or 4) x 8" duct collars

MATERIALS: 18 gauge cold rolled steel

FINISH: Powder coated baked enamel

COLOR: Grey

MOTOR/FAN(S)

- Class "B" insulated motor
- Designed for continuous operation
- Run tested for 50,000 hours
- Service: 120 Volt, 60 Hz or 230 Volt 50/60 Hz
- U.L. and C.S.A. approved

CONTROL: Variable Speed

FILTER LIFE

Stage 1: Foam Prefilter 6-12 months

Stage 2: HEPA filter: 2-5 years

Stage 3: V.O.C. filter: 6-12 months

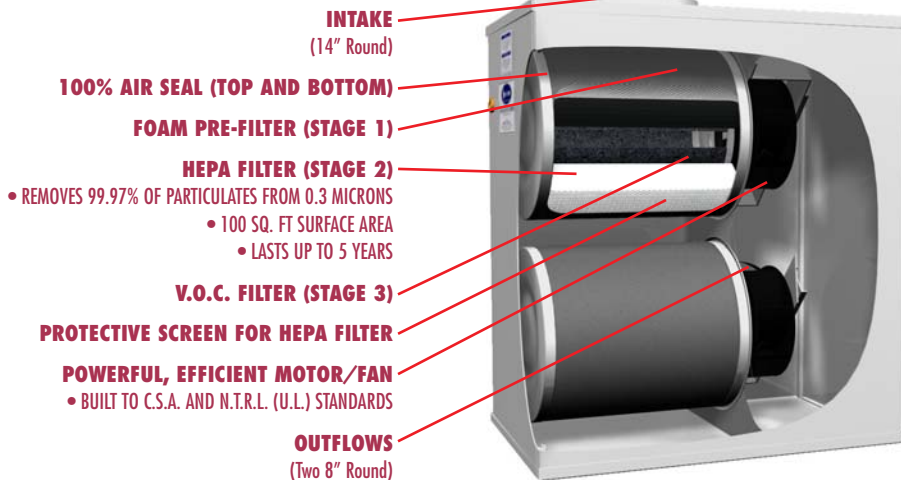

Amaircare products available at:

" InTech Marketing "
Toll free: 1-888-324-9907
www.theairpurifiers.com

